



SIEMENS

Industrial Solutions and Services

61st MEMSA Annual Meeting
September 7, 2006
Walter Koellner / SE&A
Mark Johnston / Bucyrus International

Update on Conventional and Gearless Drive Systems for Draglines

Table of Content

- **History and Barriers for Static Dragline Drive Systems W**
- **Major Components – Motors, AFEs, Inverters W**
- **Power Factor Control and Harmonics – Methology W**
- **Slide Show from 8750 Erection at Zhungeer, China W,M**

History and Barriers for Static Dragline Drive System

- Draglines with M-G set drives are in operation for nearly one century
- Evolutionary upgrades with analog and digital controls
- Reliable operation but limited with respect to efficiency, productivity, maintenance and operating costs
- Compliance with utility requirements on **voltage fluctuation at the PCC and harmonics was major barrier for static DC or AC systems on large draglines.**
- **This can be overcome for the first time in history with AFEs (Active Front End rectifiers)**
- In addition there is the option to install
 - Gearless AC Drives for the Hoist and Drag or
 - Conventional AC Drives with gears replacing the DC motors 1:1

Major Components – AC Motors

- Gearless synchronous for Hoist/Drag, induction with gears for Swing, Propel
- AC Induction Motor replaces DC Motor 1 : 1



Major Components AFE / Inverter

- Active Front End Rectifiers (AFEs) provide leading Power Factor just like M-G sets before. This makes Static Dragline Drives for the first time in history feasible.
- Water cooled IGBT (Integrated Gate Bipolar Transistor) Inverters use same technology as BI excavators and haul trucks
- Proven, reliable traction power and control hardware (SIBAS)



AFE Fundamentals

■ Power Circuit

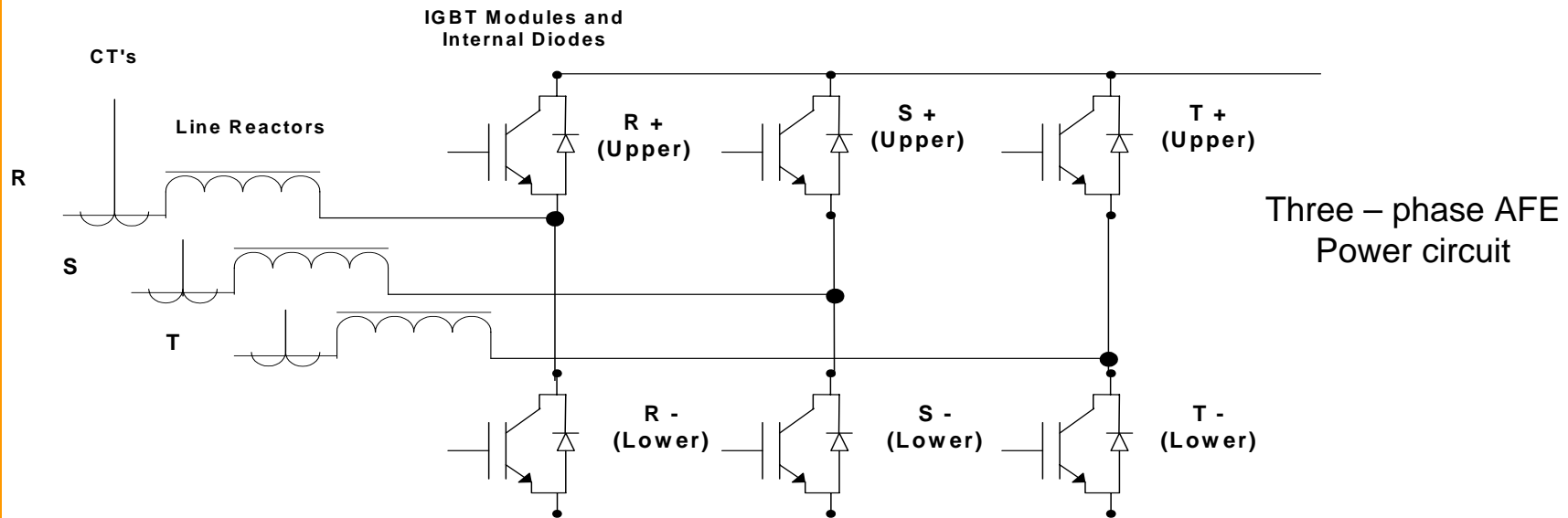

AFE 3 Phase Diagram

AFE Fundamentals

■ AFE Single Phase Diagram #1

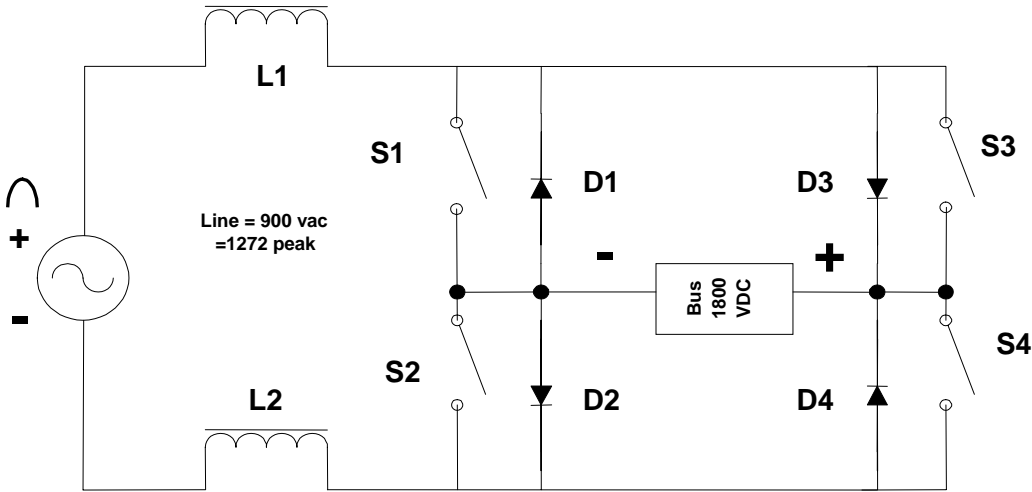

Positive Half-Cycle:
Initial State: All Switches Open

AFE Fundamentals

■ AFE Single Phase Diagram #2

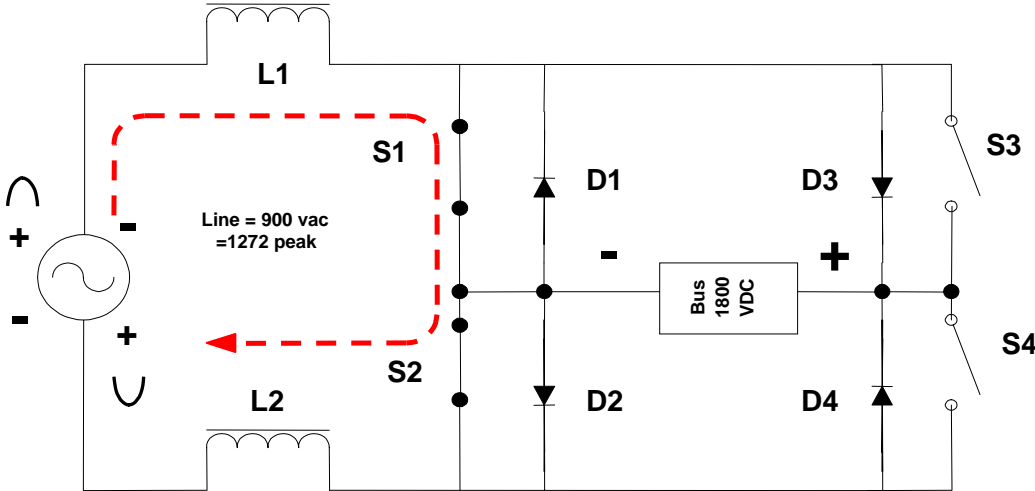

Positive Half-Cycle:
Initial State: All Switches Open

S1 & S2 Close--Causing a large current flow through L1 & L2.

AFE Fundamentals

■ AFE Single Phase Diagram #3

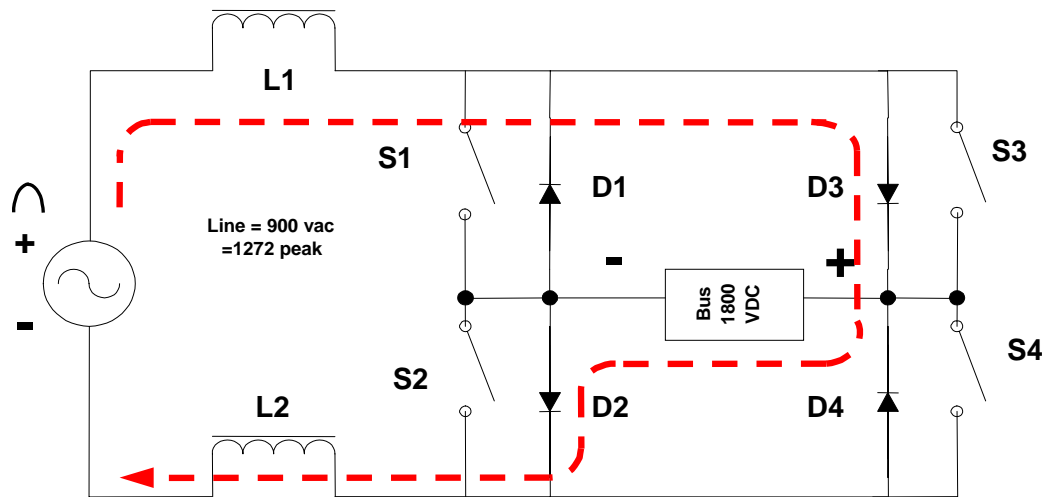

Positive Half-Cycle: Initial State: All Switches Open

S1 & S2 Close--Causing a large current flow through L1 & L2.

S1 & S2 Open--L1 & L2 try and maintain the current flow in the Same Direction.
the Voltage rises above 1800 volts, there is a current flow through D3 & D2

As

AFE Fundamentals

■ AFE Single Phase Diagram #4

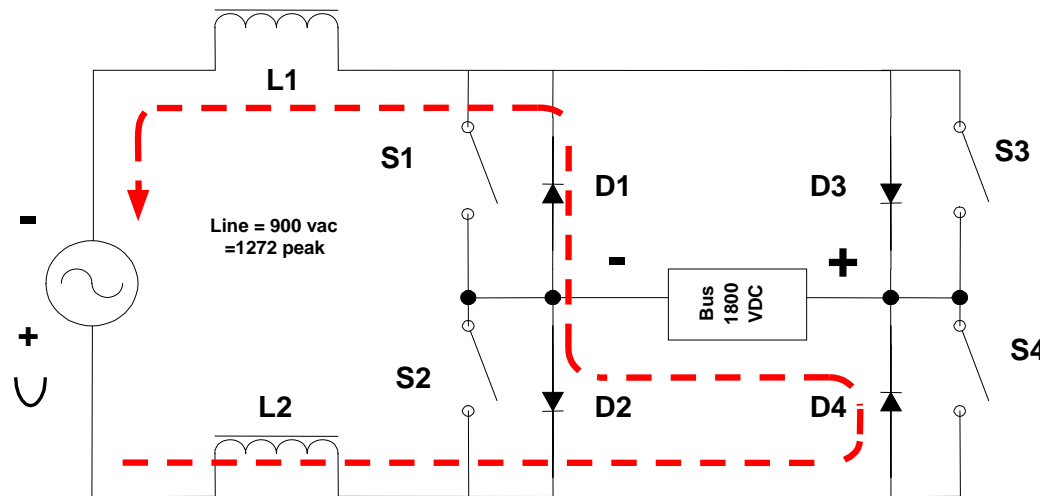

Negative Half-Cycle:

Initial State: All Switches Open

S3 & S4 Close--Causing a large current flow through L1 & L2. The Current is in the opposite direction compared to the positive half-cycle.

S3 & S4 Open--L1 & L2 try and maintain the current flow in the same Direction. As the Voltage rises above 1800 volts, there is a current flow through D4 & D1

AFE Fundamentals

■ Control Circuit

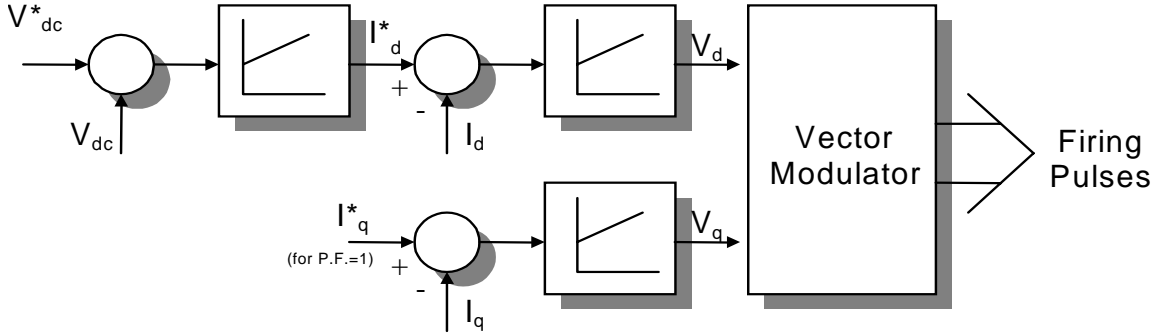

Simplified control system

AFE Fundamentals

- Motoring: The AFE supplies VARs to the line depending on the inverter voltage amplitude

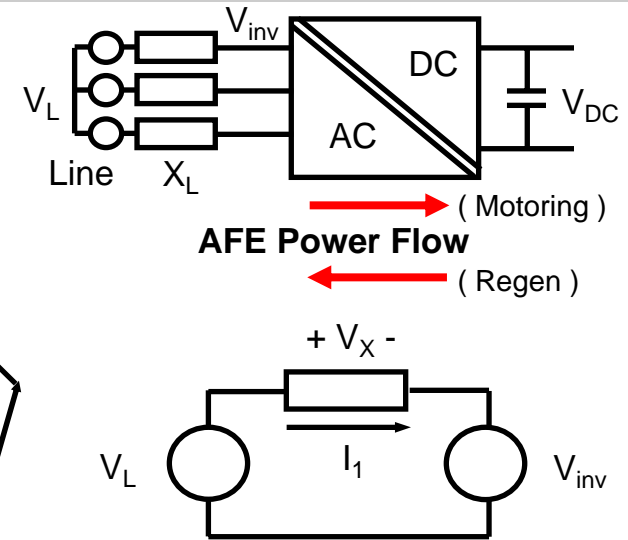
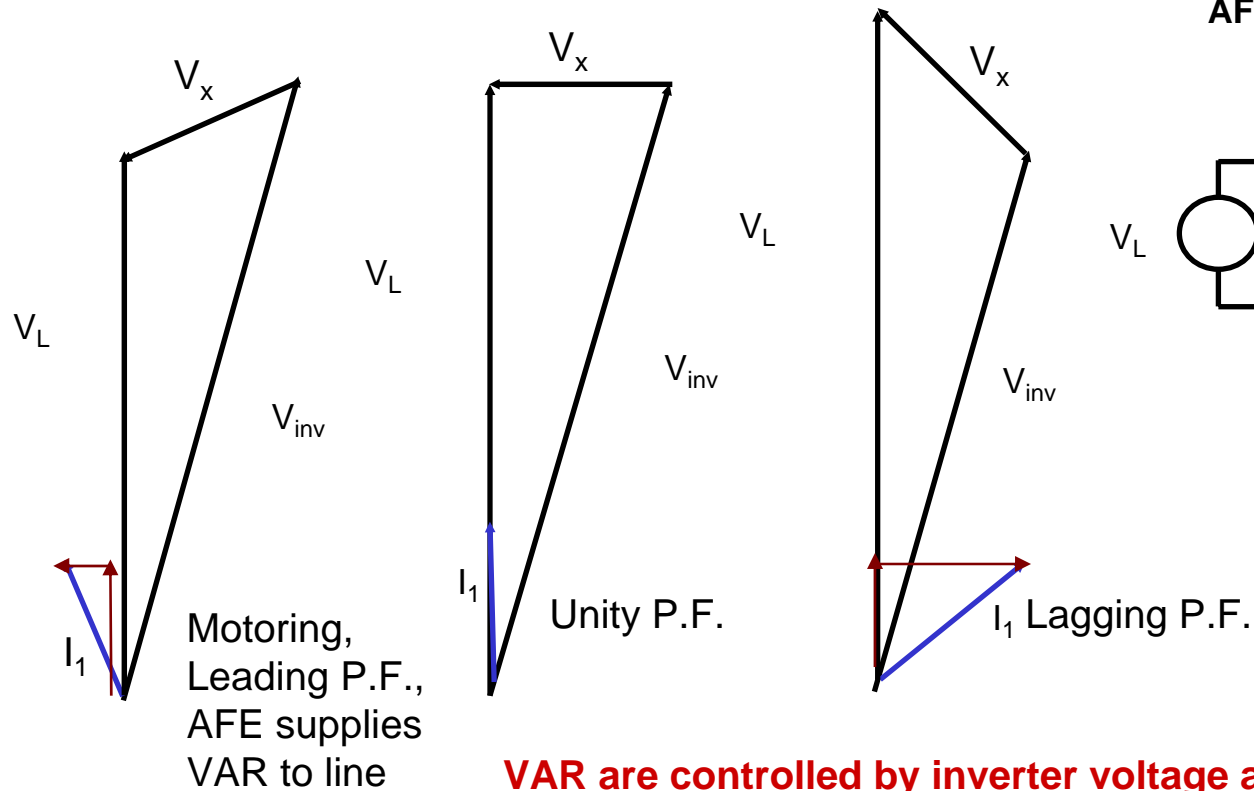

VAR are controlled by inverter voltage amplitude = modulation = excitation

AFE Fundamentals

■ Staggered Operation

- ◆ In staggered mode the 24 AFE's are synchronized with the firing pulses shifted by 1 degree (PP15, 24AFEs=360/15/24)
- ◆ Result:24x900 Hz=21.6KHz effective switching frequency and lowest THD

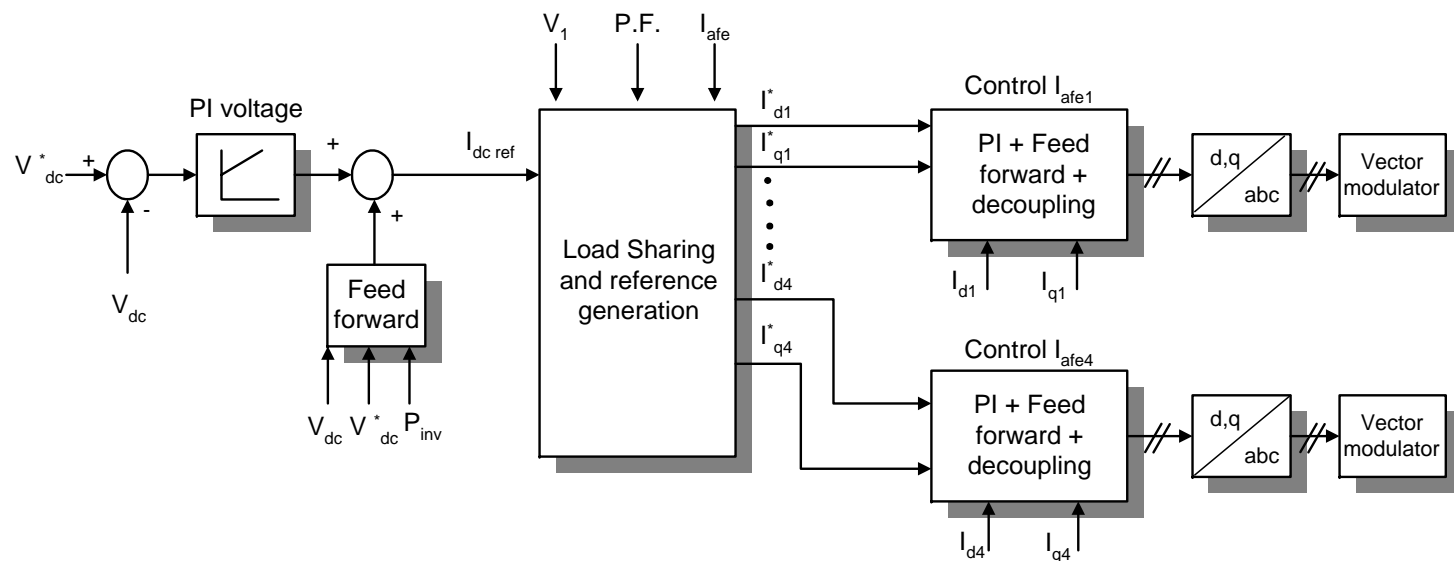

Control system for staggered AFEs

IGBT Inverters



Water-cooled IGBT Phase Module same for AFE and inverter

- IGBT (Integrated Gate Bipolar Transistor) Inverters
- Common Technology with BI Excavators & Trucks
- Reliable Traction control system
- Enhanced Diagnostics and Maintenance Support

Proven, Reliable Technology

SIEMENS

SIMINE

IGBT Advantages

- IGBT's utilize simple, reliable, gate drivers without snubbers and di/dt reactors
- IGBT's can safely turn-off overload currents without damage (GTO's fail if overloaded even momentarily)
- High switching frequency means smoother currents
- Water cooled or air cooled
- NO Fuses

Inverter Cabinet Dragline



SIEMENS

SIMINE

Inverter Cabinet Dragline

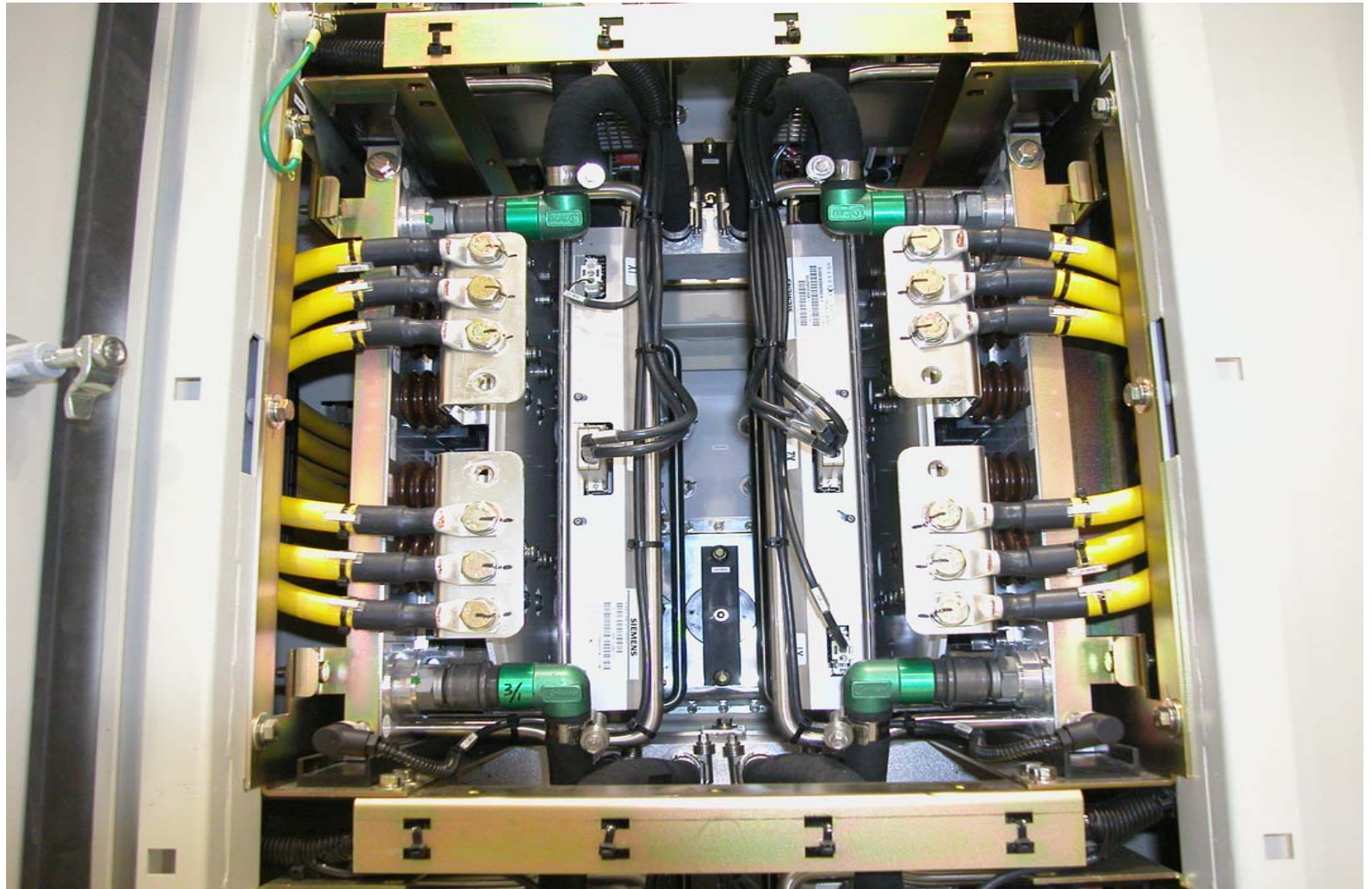

SIEMENS

SIMINE

Single Line Diagram Hoist / Drag

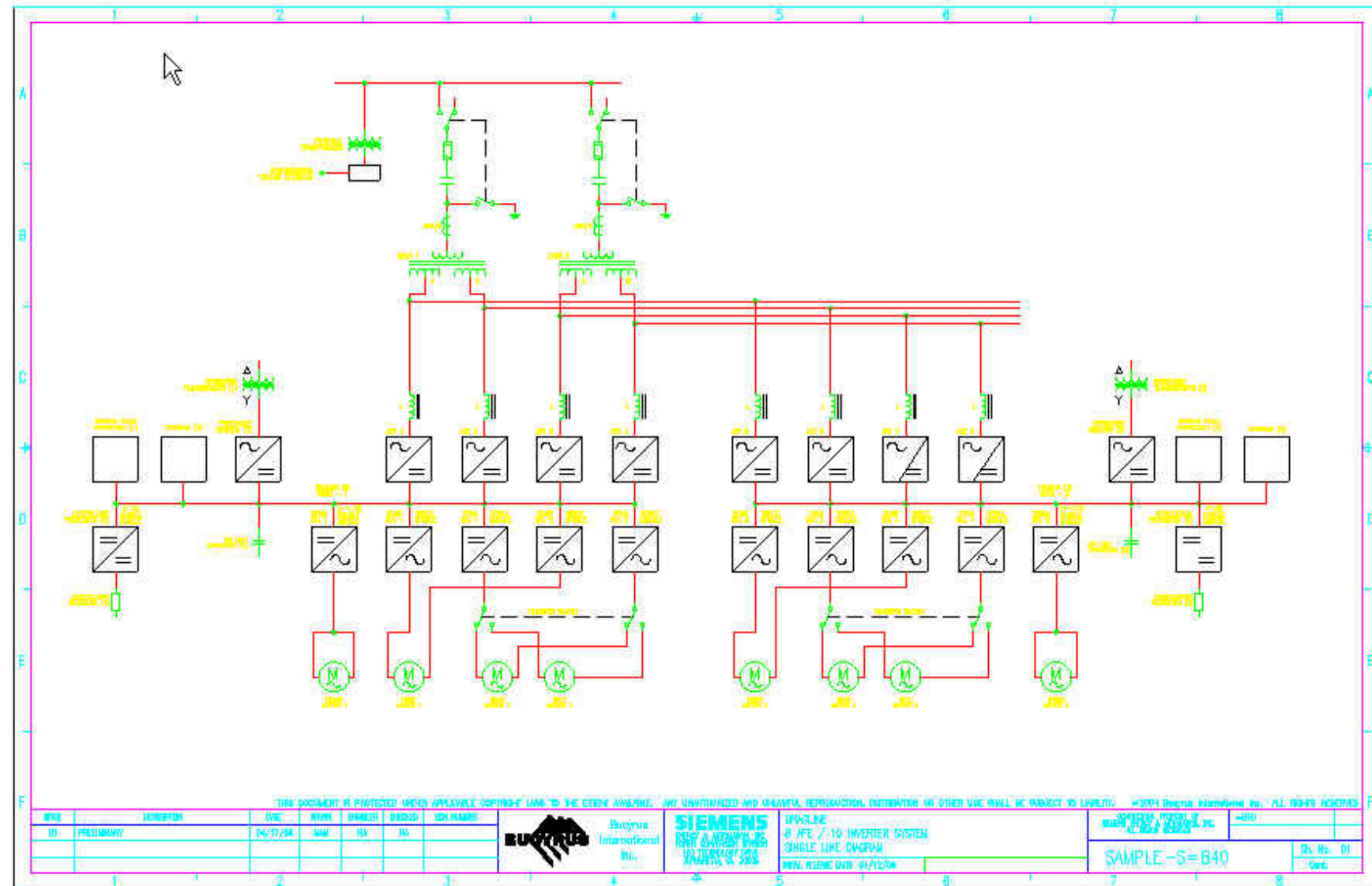

P.F., Harmonics - Methodology of Analysis

1. Create single line diagram of distribution system and loads
2. Convert to per unit values
3. Create condensed single line diagram for analysis
4. Set voltage level at PCC to 1 (100%) with new dragline off and all other loads present
5. Study voltage fluctuation at PCC and other network points with new dragline peak motoring and generating loads.
6. Define leading PF for motoring and generating loads which reduces the voltage fluctuation at PCC to 0.1% (1.001, 0.999)
7. Define THD created by the dragline drive system
8. Expand model with line and other capacitances and check for resonance frequencies.

Example to 1.

1. Create single line diagram of distribution system and loads

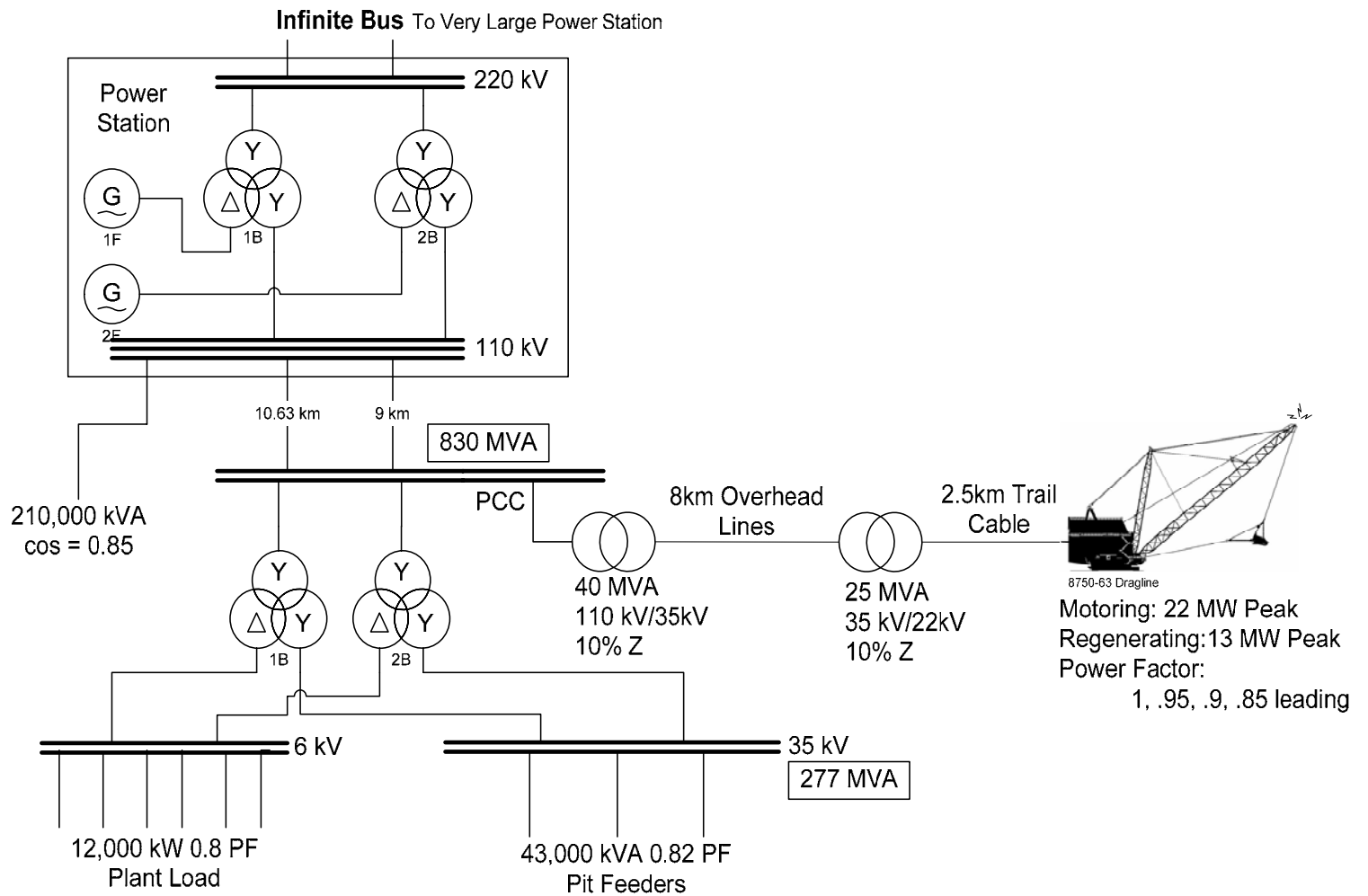

Example to 2., 3.

2. Convert to Per Unit Values

kVA base = 100,000 kVA

kV base = 110 kV

3. Create condensed single line diagram for analysis

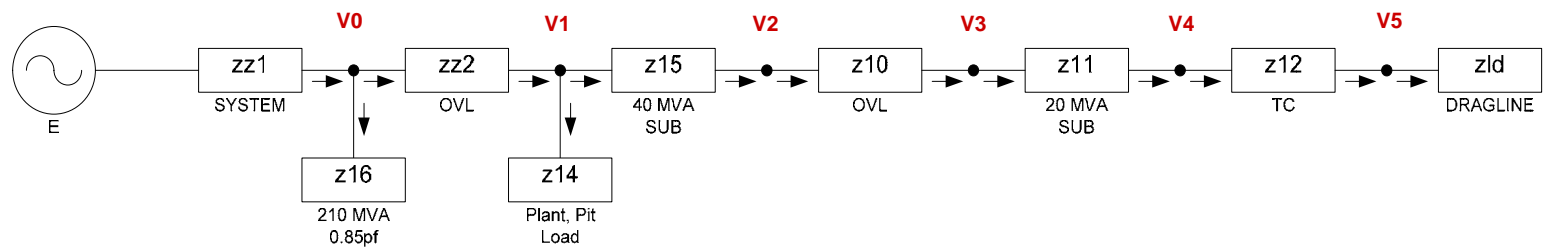

Example to 4.

4. Set voltage level at PCC to 1 (100%) with new dragline off and all other loads present

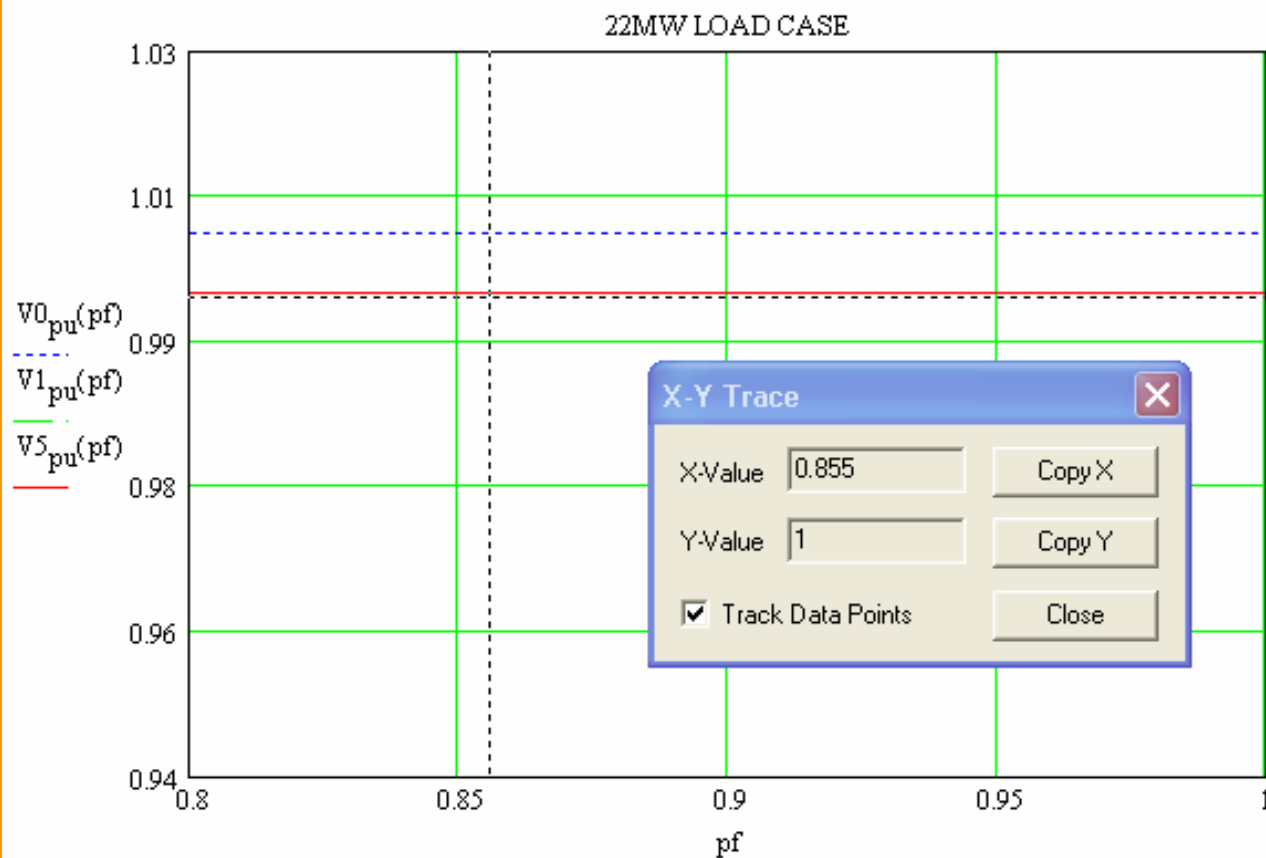

Example to 5., 6.

6. Define leading PF for motoring and generating loads which reduces the voltage fluctuation at PCC to 0.1% (1.001, 0.999)

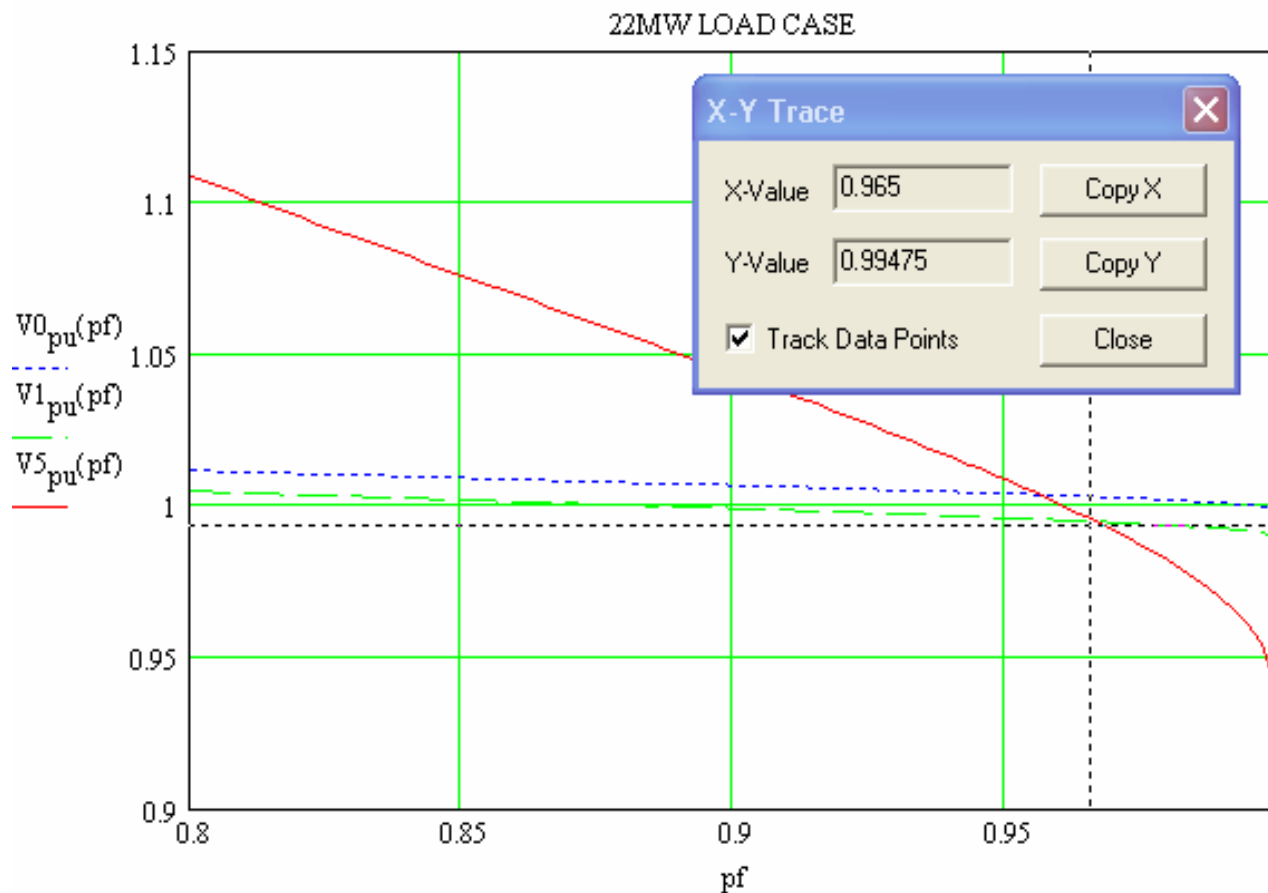

	22MW motoring pf = 0.965
V1 _{pu}	0.9947
V5 _{pu}	0.9961

Example to 5., 6.

6. Define leading PF for motoring and generating loads which reduces the voltage fluctuation at PCC to 0.1% (1.001, 0.999)

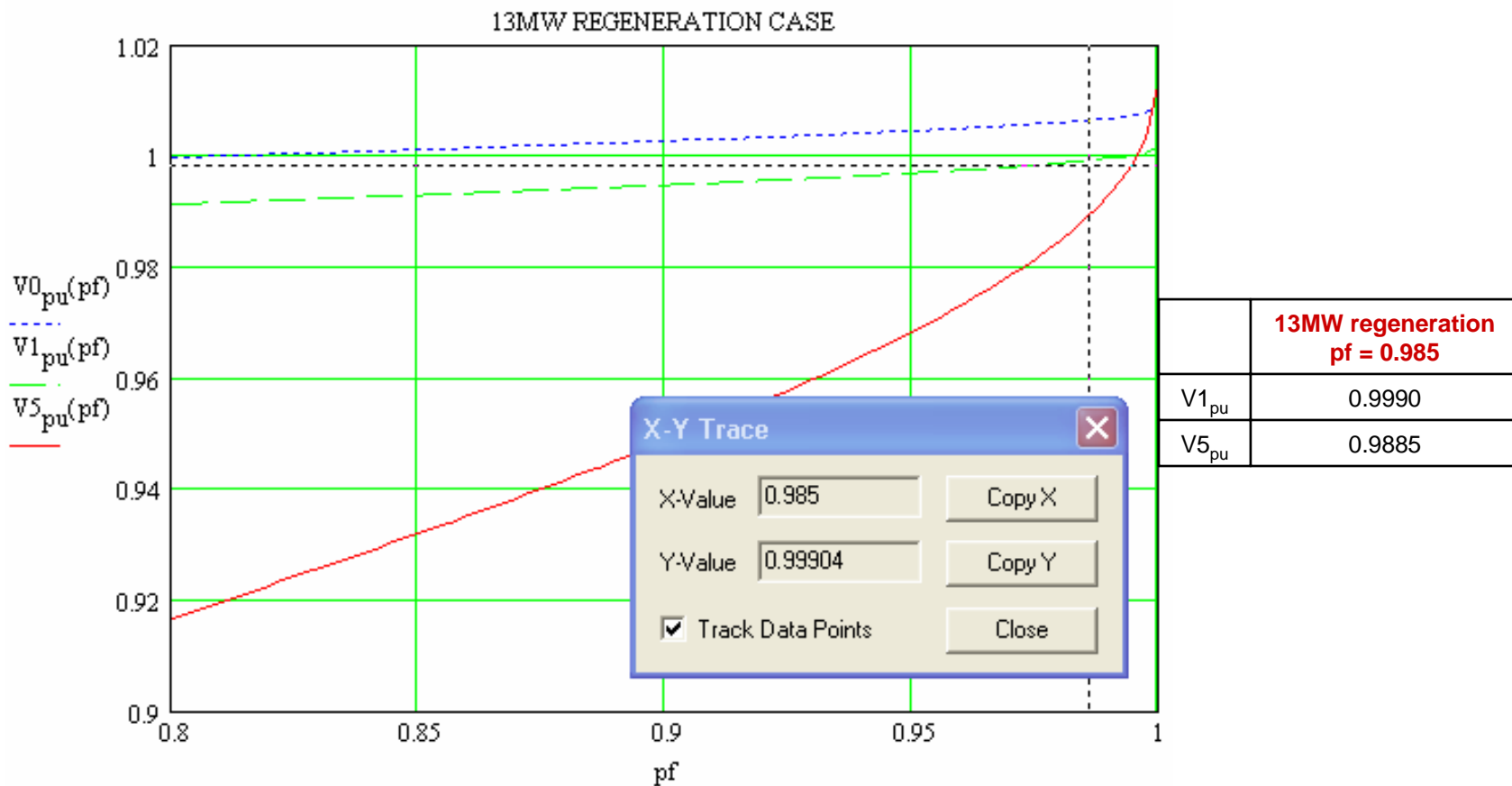

Example to 5. 6.

Evaluate Voltage Swing at PCC over complete duty cycle

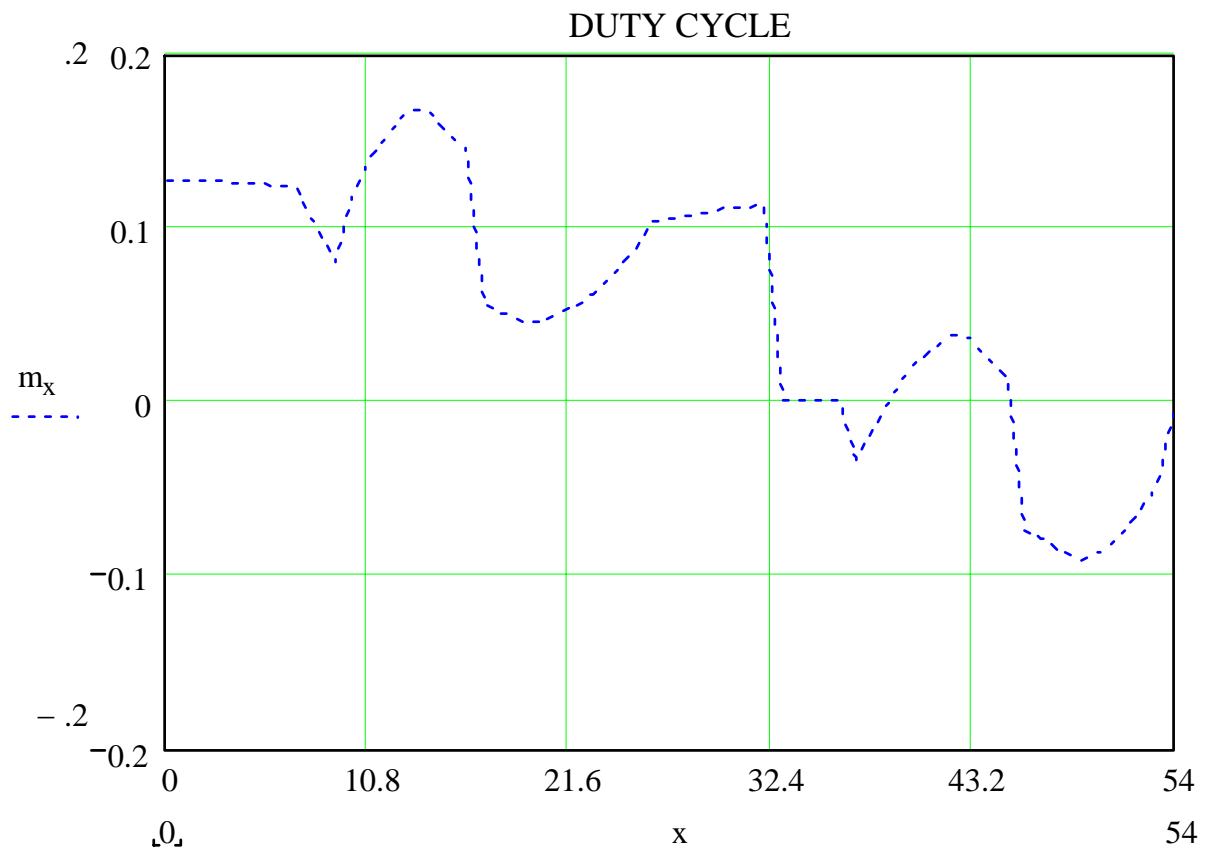

Example to 5. 6.

Evaluate Voltage Swing at PCC over complete duty cycle w/o auxiliaries

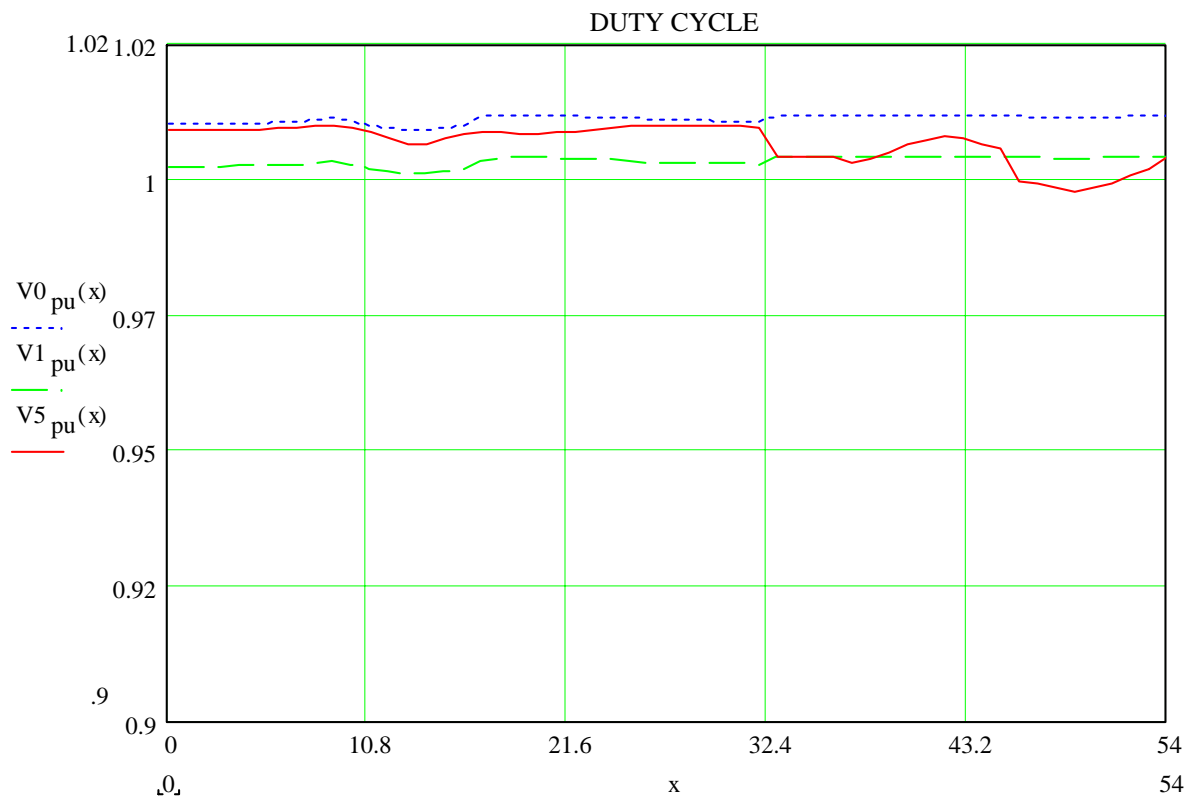

	maximum	minimum	delta
$V1_{pu}$	1.0002	0.9970	0.0032
$V5_{pu}$	1.0056	0.9940	0.0116

Example to 8.

8. Expand model with line and other capacitances and check for resonance frequencies.

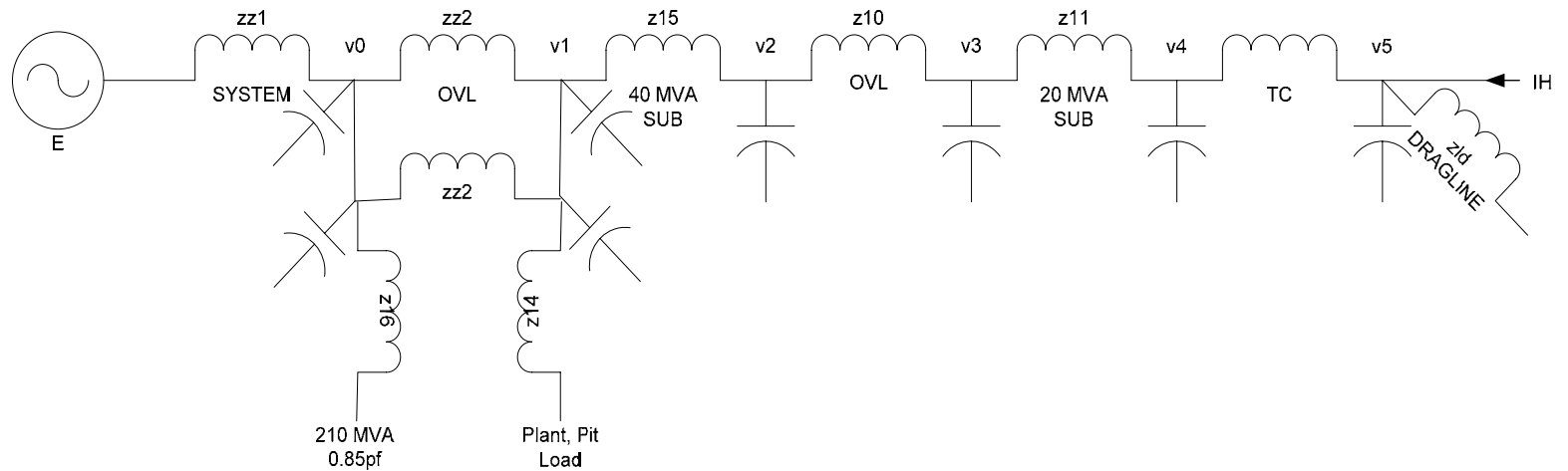

Example to 7.

7. THD and harmonic spectrum at primary of MPT on dragline → 1.17%

Harmonic Current Spectrum and IEEE519 standard @ 22kV

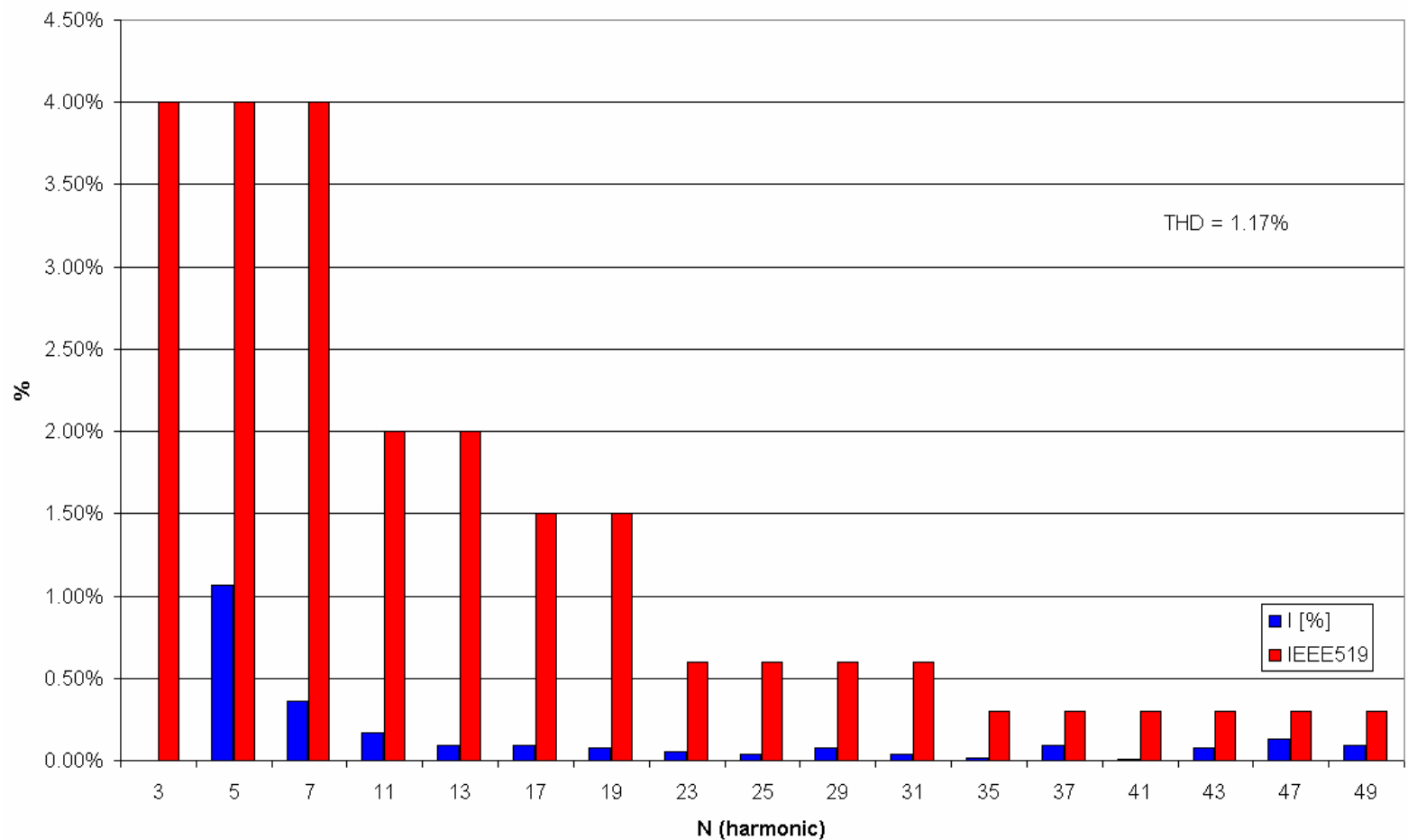

Example to 8.

8. e.g. 23rd harmonic produces 20% resonance

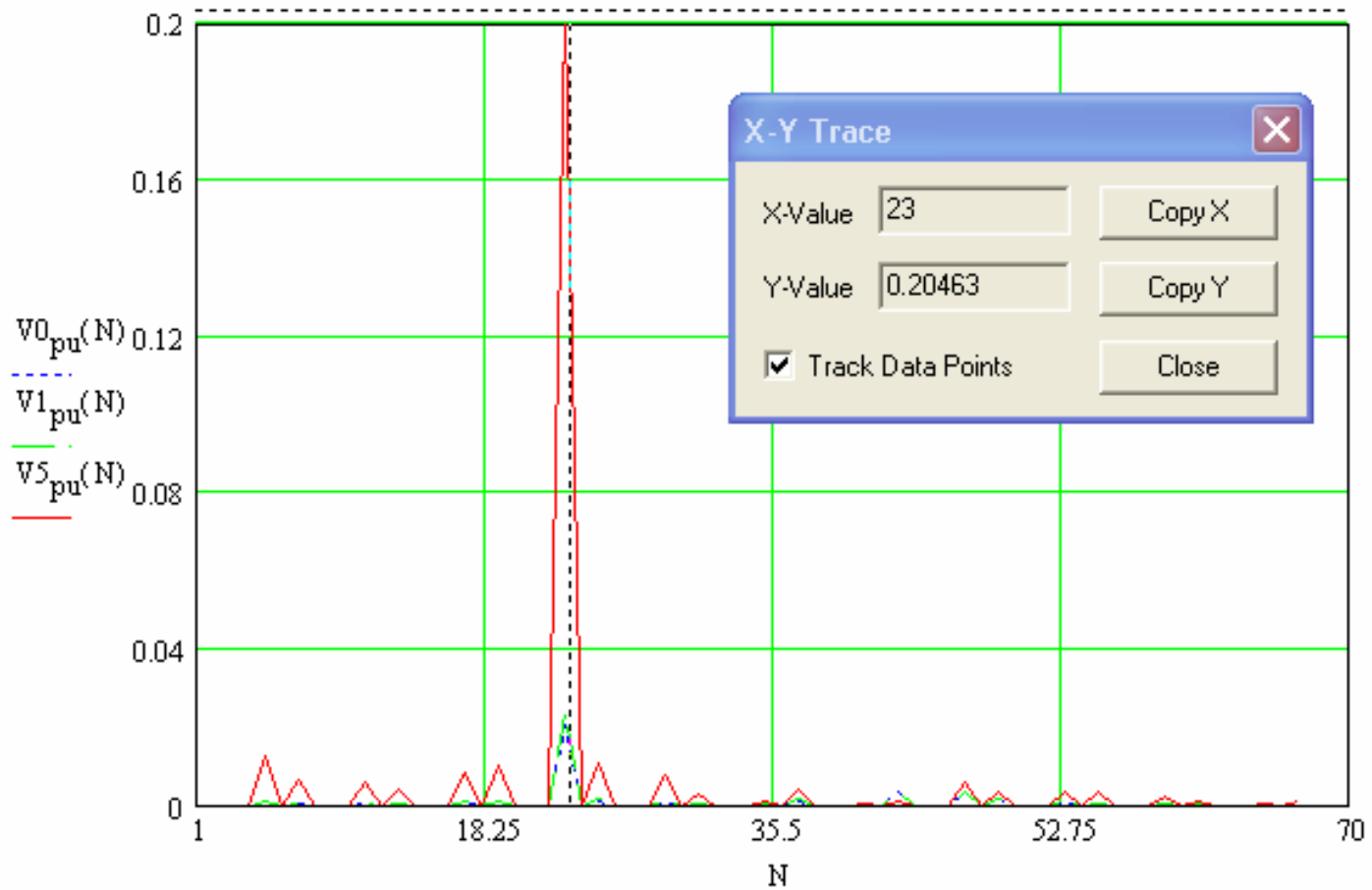

Photos 8750 Erection Zhungeer, China



SIEMENS

SIMINE